

Powering High Brightness LEDs in Camera Phones

High-end camera phones are greatly improving, with better lenses and higher resolution, but they need a better light source for taking photos in low light. Until now, high-end phones such as Sony Ericsson's K850 and Nokia's N82 have used a xenon flash. However, the large electrolytic capacitor in these xenon solutions precludes slimline phones. A new solution with a total thickness of less than 3 mm is now possible using very high-brightness LEDs and CAP-XX supercapacitors.

Light Energy Required for Good Photos

Clear photos require that sufficient light energy is received by each pixel in the camera sensor during image-capture time. What naturally draws our attention, however, is light power or brightness of the flash.

Light energy is the area under the curve of light power over time. To calculate it, integrate light power (measured in lux) over duration of the flash exposure (in seconds). For constant LED light power:

$$\text{Light power (lux)} \times \text{flash exposure time (secs)} = \text{light energy (lux.secs)}$$

Xenon flashes have excellent light power, up to several hundred thousand lux, but a very short pulse duration, typically 50 to 100 μsec . A high-quality xenon camera-phone flash typically delivers between 10 to 15 lux.secs of light energy at 1 m distance from the subject (Figure 1).

LED flashes deliver lower light power, but sustain a longer pulse to generate sufficient light energy. Today's high-end LED-flash camera phones typically drive one or two LEDs at up to 300 mA each delivering 50 to 70 lux. In low light, the camera sensor will drop to 7.5 frames/second, so each pixel integrates light for $1/7.5 = 133 \text{ ms}$. Total light energy = two LEDs by 0.133 by 60 = 16 lux.secs. However, such a camera sensor uses a rolling shutter, so the total image-capture time is double the frame period or 267 ms. This long image-capture time results in blurry photos if the photographer's hand shakes or the subject moves.

Power Required for LED Solution

What we previously described was a standard battery-powered LED flash solution: at 300 mA, LED V_F ranges from 3 V to 3.5 V, so the maximum power drawn for 2 LEDs is 0.3 A by 3.5 V by 2 = 2.1 W. A Li-Ion mobile-phone battery can handle this solution.

However, to deliver enough light energy in a shorter pulse to take a

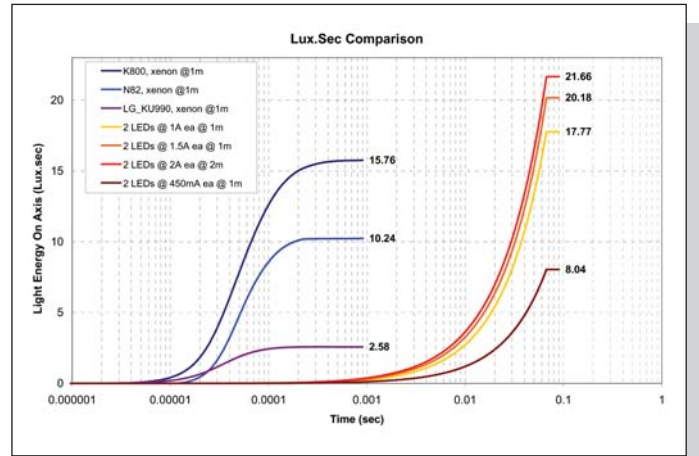

Figure 1. Light energy over time for various flash sources. Time is on a log scale to show light energy for both xenon flash (< 200 μs) and LED flash (up to 67 ms). For LED Flash, read the light energy for a given pulsewidth, e.g. for 2 A/LED, there is 20 lux.secs after 30 ms.

good photo, much higher light power is required. Ideally, exposure time should be more than $\sim 30 \text{ ms}$ so handshaking will not cause blur. To deliver 10 lux.secs in 30 ms, two LEDs should generate $\sim 170 \text{ lux}$ each. For high-power LEDs from vendors such as Philips Lumileds or Seoul Semiconductor this requires $\sim 2 \text{ A}$ per LED. At 2 A, V_F is $\sim 4 \text{ V}$, so total LED power is 16 W for two LEDs with $\sim 0.8 \text{ W}$ overhead for current control. Using a traditional current-controlled boost as an LED driver at 90 percent efficiency, the battery needs to deliver $\sim 19 \text{ W}$ or $\sim 7 \text{ A}$ for a battery at 3.7 V with 150 $\text{m}\Omega$ impedance.

A lower-power alternative is a rolling shutter running at 15 frames/second, so each pixel integrates light over 67 ms with LED current halved to 1 A for each of two LEDs. Light power then becomes $\sim 120 \text{ lux/LED}$ so light energy is 16 lux.secs, comparable to the SonyEricsson K800i (Figure 1). At 1 A, V_F is $\sim 3.6 \text{ V}$ with approximately 0.4 W overhead for current control so using the same assumptions as the 4 A case above, battery current now becomes 2.5 A for 133 ms. Neither the 4 A nor the 2 A case is practical.

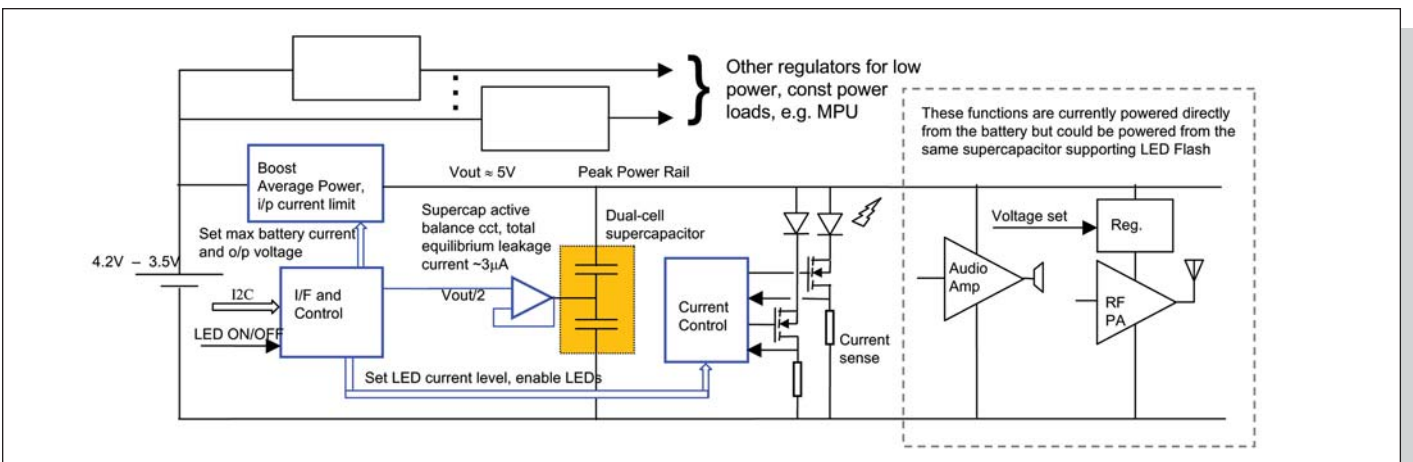

Figure 2. BriteFlash power architecture for high-power LED flash using a supercapacitor

BriteFlash Power Architecture for High-Current LED Solution

To achieve high LED power, designers can add a thin supercapacitor to deliver peak flash-power, using the battery to cover average power needs (Figure 2).

Between flashes, the LEDs require one to two seconds to cool, and the supercapacitor requires the same time to re-charge. Consider a 4 A pulse lasting 30 ms once per second. If the boost is 90 percent efficient, then the average battery current = $5\text{ V}/3.7\text{ V} \times 4\text{ A}/90\text{ percent} \times 30\text{ ms}/1\text{ s} = 180\text{ mA}$. Or, for a 2 A pulse lasting 133 ms, the average battery current = $5\text{ V}/3.7\text{ V} \times 2\text{ A}/90\text{ percent} \times 133\text{ ms}/1\text{ s} = 400\text{ mA}$. The battery can easily handle either case.

Because component volume is at a premium inside a mobile phone, designers must balance the flash pulse that can be supported with the physical size of the supercapacitor. Supercapacitor voltage at the end of the flash pulse =

$$\text{Initial Voltage} - (\text{Flash current} \times \text{Supercapacitor ESR} + \text{Flash current} \times \text{Flash pulsewidth}/\text{Capacitance}). \quad (1)$$

This final voltage should be less than V_f + the voltage across the current-sense resistors shown in Figure 2. Organic-electrolyte supercapacitors with a maximum voltage rating per cell up to 2.75 V are better-suited to the LED-flash application than aqueous-electrolyte supercapacitors with a maximum cell rating of ~1 V. The 425 mF, 110 mΩ, 5.5 V dual-cell HA230 CAP-XX supercapacitor which measures 20 mm by 18 mm by 3.2 mm is tailored for this solution (Figures 3a and 3b).

To attract major handset manufacturers, the supercapacitor-driven LED flash power architecture in Figure 2 needs to be integrated. Several major IC vendors have, or will soon, release supercapacitor-optimized flash-driver ICs to integrate the circuitry to save development time, board space and component cost.

Two such ICs available now are the AAT1282 from AnalogicTech (Figure 3a), and the NCP5680 from ON Semiconductor (Figure 3b). Both have integrated the blue-outlined functions in Figure 2. The voltage-controlled boost can be either a charge pump or inductor-based. AnalogicTech and ON Semiconductor implemented a charge pump. Both ICs have an I2C interface to set key parameters. The AAT1282 has also integrated the current-sense elements and current-control FETs which reduces size and complexity but limits the maximum flash current. The NCP5680 uses external FETs and current-sense resistors so the maximum flash current is only constrained by the LEDs or supercapacitor energy and power.

Figure 2 shows how the supercapacitor can multitask to support other peak-power functions in the phone. When doing so, the supercapacitor must remain charged. When only supporting the flash function, it needs to be charged only while the phone is in camera-mode. Supercapacitor leakage and balancing current should be minimized if the supercapacitor is always charged. The NCP5680 provides an active balance circuit as shown in Figure 2 to achieve this while with the AAT1282 the user must fit a pair of balancing resistors across the supercapacitor cells.

Sizing the Supercapacitor and Setting Maximum Battery Current

To confirm suitability of the HA230 supercapacitor, calculate its final voltage at the end of the flash pulse. Set the output of the boost to 5.3 V, which is slightly less than the maximum supercapacitor voltage of 5.5 V. From equation (1), for the 4 A, 30 ms-flash-pulse case, the final supercapacitor voltage = $5.3\text{ V} - 4\text{ A} \times 0.11\ \Omega - 4\text{ A} \times 0.03\text{ s}/0.425\text{ F} = 4.6\text{ V}$. If the current-sense voltage = 200 mV, then the HA230 will support the flash pulse if $V_f(2\text{ A}) < 4.4\text{ V}$. For the 2 A, 133 ms case, the final supercapacitor voltage = $5.3\text{ V} - 2\text{ A} \times 0.11\ \Omega - 2\text{ A} \times 0.133\text{ s}/0.425\text{ F} = 4.45\text{ V}$. Again if the current-sense voltage = 200 mV, then the HA230 will support the flash pulse if $V_f(1\text{ A}) < 4.25\text{ V}$.

We demonstrated earlier that the average current with one-second intervals between flash pulses is much less than the maximum current the battery can easily deliver. Set the maximum input current to the flash-driver IC through the I2C interface so the time to charge the supercapacitor is acceptable and the battery is not overloaded.

There are two cases to consider when determining the time to charge the supercapacitor:

- From zero volts, when users first select camera-mode =

$$\text{Output voltage} \times \text{capacitance}/\text{charge current}. \quad (2)$$

If the maximum battery current is set = 800 mA, then the supercapacitor charge current = $800\text{ mA} \times 3.6\text{ V}/5.3\text{ V} \times 90\text{ percent} = 490\text{ mA}$. Therefore, time to charge the HA230 from zero volts = $5.3\text{ V} \times 0.425\text{ F} / 0.49\text{ A} = 4.6\text{ secs}$.

- Between flash photos =

$$= \text{Flash current} \times \text{Flash Pulsewidth} / \text{Charge Current}$$

= $4\text{ A} \times 0.03\text{ secs}/0.49\text{ A} = 0.25\text{ s}$ for the 4 A, 30 ms-flash-pulse case and = $2\text{ A} \times 0.133\text{ s}/0.49\text{ A} = 0.5\text{ s}$ for the 2 A, 133 ms-flash-pulse case.

Comparison with Xenon

Figure 1 compares the light energy between various xenon solutions and high-powered LED flash. LED-flash solutions using a rolling shutter at 15 frames/sec demonstrate considerably more light energy than xenon camera-phones: two LEDs at 2 A deliver 30 percent more than the SonyEricsson K800i, and 50 percent more than the Nokia N82.

Figure 1 also shows that small xenon solutions, which use a 10 to 15 μF 330 V storage capacitor to save space and cost, deliver poor light-energy performance. The LG Viewty KU990 delivers only 2.6 lux.secs of light energy. The large electrolytic capacitor plus the xenon tube and associated circuitry make the xenon solutions considerably bulkier than the supercapacitor ones.

Figure 3 compares supercapacitor-powered LED flash solution thinness to xenon.

Finally, seeing is believing. Figure 4 compares three photos taken in a dark room at approximately 2 m distance.

The supercapacitor-powered LED

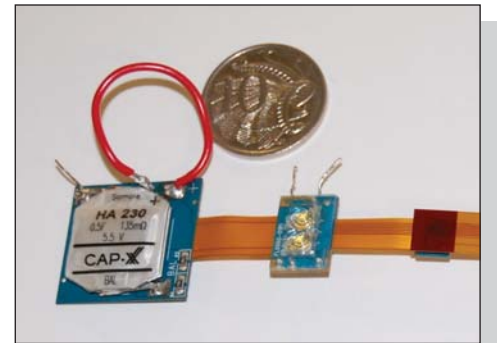

Figure 3a. Supercapacitor LED flash module with CAP-XX HA230 supercapacitor, AnalogicTech AAT1282 flash driver on the reverse side and Seoul Semiconductor LEDs.

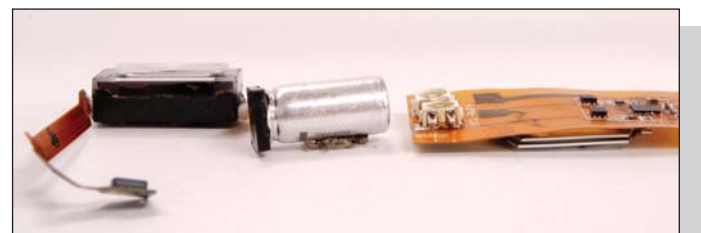

Figure 3b. Supercapacitor LED flash module with the CAP-XX HA230 on the underside, ON Semiconductor's NCP5680 flash driver and Lumileds LEDs. Also pictured is the Nokia N82 xenon solution with large cylindrical electrolytic.



Small xenon flash using 10 mF storage capacitor



SonyEricsson K800i with high quality xenon flash



Nokia N73 modified with a CAP-XX supercapacitor to use 3 x Lumileds PWF1 LEDs at 0.9 A each.

Figure 4. Comparison of photos with normal LED flash, xenon and supercapacitor-supported high-powered LED Flash

flash solution takes a much better photo than a phone that used a small xenon flash and at least as good if not better than a leading xenon camera-phone, in a thinner form-factor and at 5 V without the safety concerns of a 330 V-electrolytic capacitor nor the high-voltage trigger circuit ($>4,000$ V).

This article has shown how to drive LEDs at very high power, up to 16 W, using a supercapacitor to support a mobile-phone battery. Such a high-powered LED solution delivers more light energy than a xenon flash in a thinner form-factor more compatible with today's slimline phones. Example photos comparing standard battery-powered LED Flash, xenon

and high-powered LED flash demonstrate the excellent performance of the high-powered LED flash solution.

Pierre Mars is the vice president of applications engineering for CAP-XX Ltd. He jointly holds three patents on supercapacitor applications. Mars has a BE electrical (1st class honors) and an MEng Sc from the University of NSW, Australia, in addition to an MBA from INSEAD, France. He is also a member of the IEEE. Mars can be reached at sales@cap-xx.com.

FREE YOUR PRESS

If industry experts are writing about your company, shouldn't you spread the word?

Your customers, prospects and employees need to know:

- How your company delivers exceptional value to your market
- The unique benefits of your products or services
- When you do something innovative that helps your customers

Unlock the value of your editorial and reach beyond this publication. Contact The YGS Group today to request customized reprints of your coverage.

LED Journal

The Magazine of Solid-State Lighting

The YGS Group is the authorized provider of custom reprint products and content licensing from Webcom Communications Corporation.

Our clients use reprints to support their marketing efforts through:

- Recruiting Packages
- Direct Mail
- Event Collateral
- Online Marketing
- Media Kits
- Trade Shows



800.290.5460

LEDjournal@theYGSgroup.com

www.theYGSgroup.com/reprints